

Noctis Hanter Table Light

Bold, ebonised design and our sought-after wooden aesthetic, merged. With confidence in its definitive silhouettes, The Noctis Range showcases a new focus and brings daring, darker depths to interiors.

Modern. Refined. Enticing. An arching curve of steam bent, black ebonised oak arches from its roots to showcase an exposed bulb which casts a boundless glow. Use the statement Noctis Hanter Table Light to restore calm within bustling kitchens, hallways or living spaces. Radiating light in all directions, the wooden table lamp blends an inviting ambience with a sharp design aesthetic.

Invite darkness into the light.

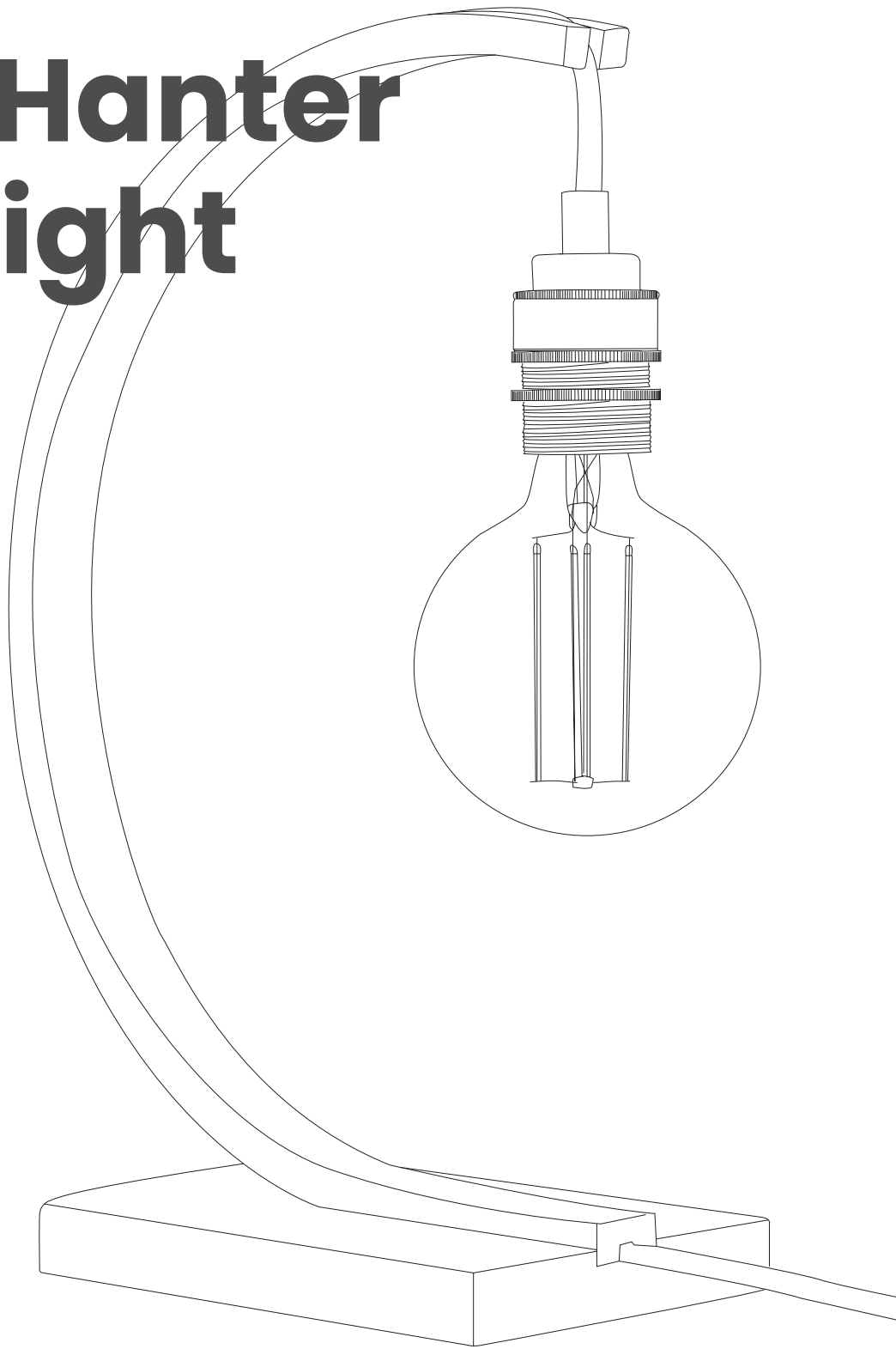

DISCLAIMER

Due to the character of handcrafted natural products, all dimensions are approximate. Wood colour may slightly vary. All product details are correct at time of print and are subject to change without notice.

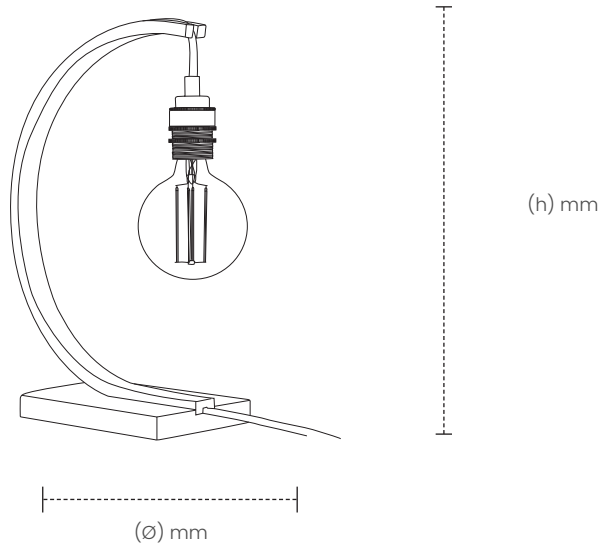

NOCTIS HANTER TABLE LIGHT

SKU

NOCTIS: TR-NCT-HAN-TBL

DIMENSIONS
L X W X H (mm)

UNBOXED: 250 X 130 X 380
BOXED: 540 X 312 X 165

WEIGHT
(kg)

UNBOXED: 0.95
BOXED: 1.65

COLOUR VARIANTS

Painted Beech

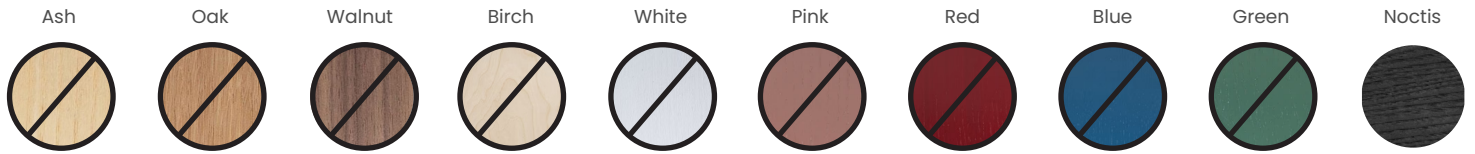

Finish: Non-toxic, hard wearing water based varnish - satin.

Additional materials: Birch ply hanging disk.

ADDITIONAL INFORMATION

Suitable for use on 240v circuits only. Not suitable for use in the USA or Canada.
Fitted with a UK plug - an adapter will be required for use outside of the UK (not provided).
Installation instructions and fixings included.

WIRING KIT INFORMATION

Separate spec sheet for product wiring information available in product page downloads.