

Hanter Table Light

A taut arc of steam bent timber clings to a solitary filament bulb. Refreshing in its simplicity, surprising in its design, our Hanter Lighting Range turns heads.

Sustainably sourced oak arches into a solid timber base. Along its curve, an exposed flex traces into a brass fitting, bringing a modern accent to a timeless, natural form. Radiating light in all directions, the Hanter blends an inviting ambience with a sharp design aesthetic.

Pair up. Create a feature. Make your mark.

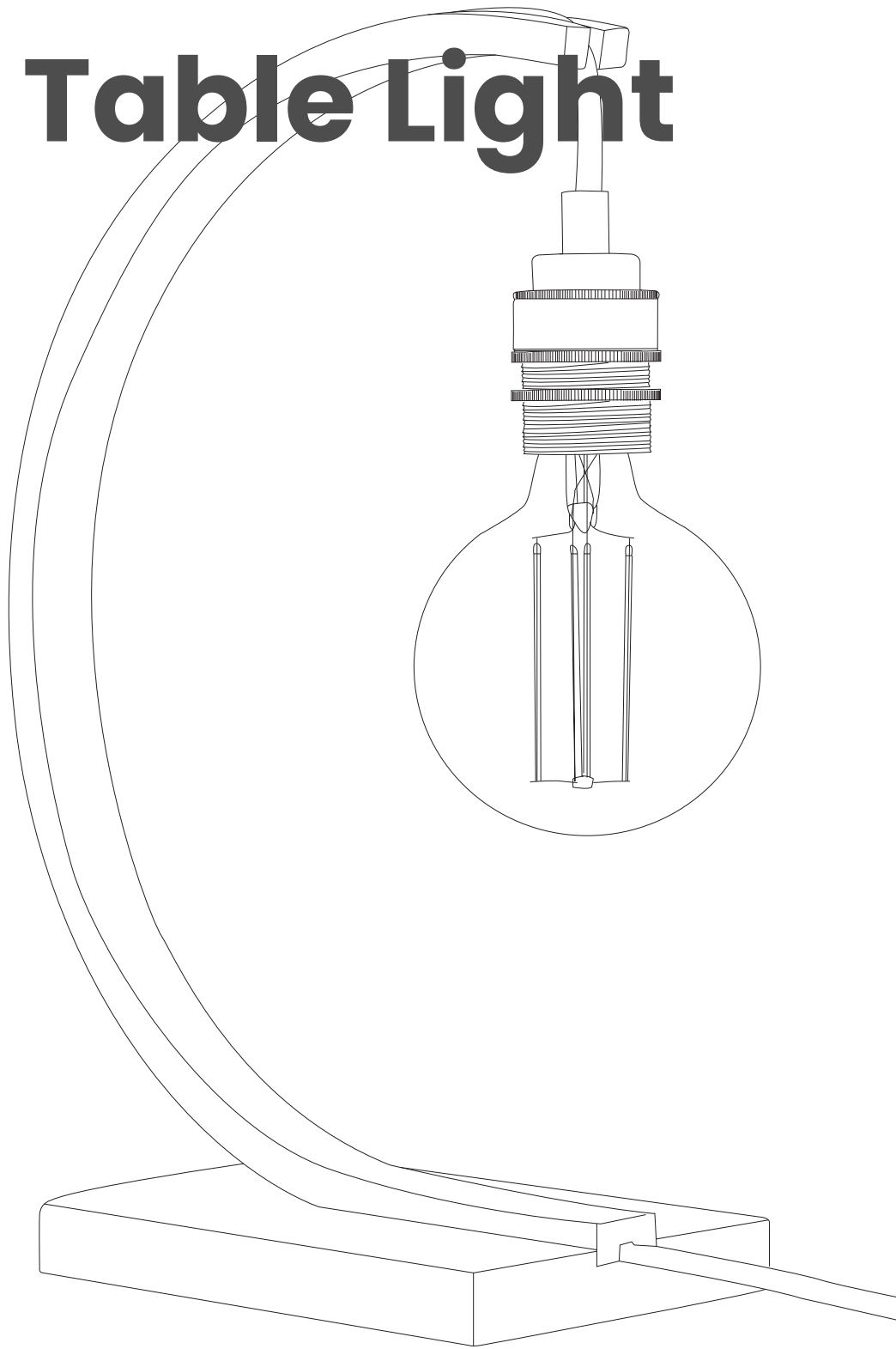

DISCLAIMER

Due to the character of handcrafted natural products, all dimensions are approximate. Wood colour may slightly vary. All product details are correct at time of print and are subject to change without notice.

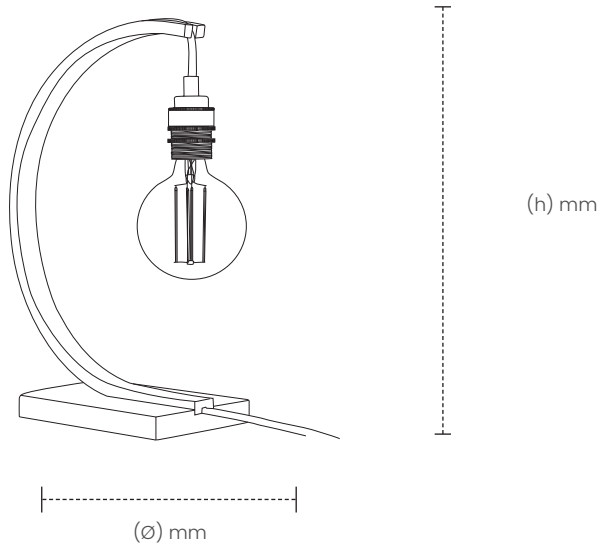

HANTER TABLE LIGHT

SKU

OAK: TR-HAN-TBL-O

DIMENSIONS
L X W X H (mm)

UNBOXED: 250 X 130 X 380
BOXED: 540 X 312 X 165

WEIGHT
(kg)

UNBOXED: 0.95
BOXED: 1.65

COLOUR VARIANTS

Painted Beech

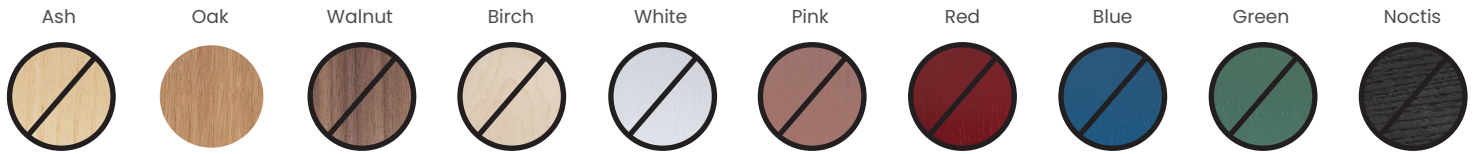

Finish: Non-toxic, hard wearing water based varnish - satin.

ADDITIONAL INFORMATION

Suitable for use on 240v circuits only. Not suitable for use in the USA or Canada.
Fitted with a UK plug - an adapter will be required for use outside of the UK (not provided).
Installation instructions and fixings included.

WIRING KIT INFORMATION

Separate spec sheet for product wiring information available in product page downloads.