

# Tom Raffield

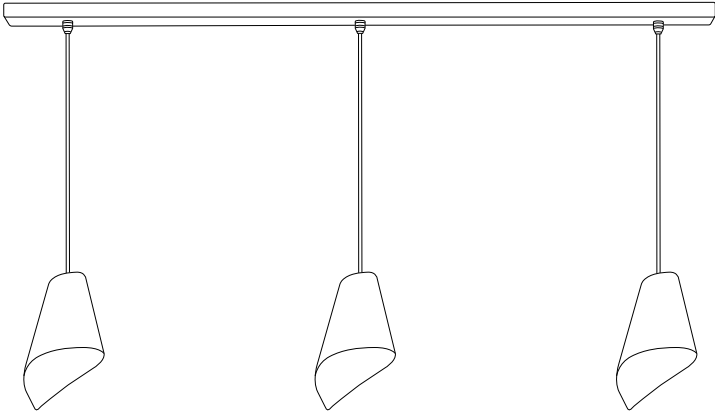

Linear Bar Pendant Lighting



Installation Instructions

---

# Linear Bar Pendant Lighting Installation Instructions

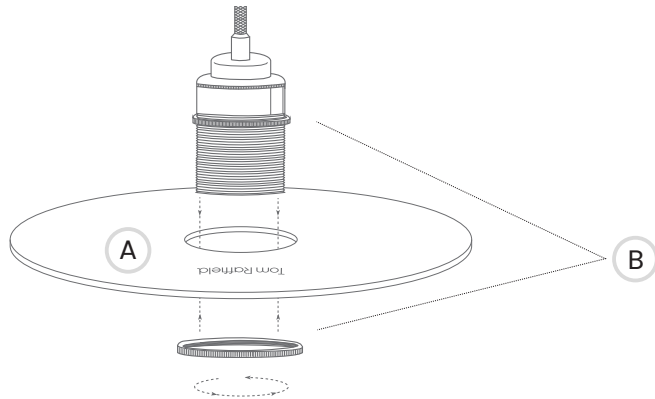

**Only qualified persons should assemble the luminaire. If in doubt, consult a suitably qualified person. Installation MUST be carried out in accordance and compliance with current building regulations.**

**Ensure the electrical supply is turned OFF at the fuse board.**

1. Identify if there are any hidden pipes or electrical cables in the ceiling to avoid causing damage or risk of electrical shock during installation. Determine the fixing method appropriate to the ceiling structure, e.g. plasterboard plugs. We always recommended that the light fitting is secured to a suitably strong joist or beam.
2. Before attaching the wooden bar to the ceiling, each pendant should be adjusted to the desired drop height. Loosen the cord grip at the top of each pendant drop. Excess wire can be carefully coiled into the recess of the wooden bar or ceiling. Tighten the cord grips to securely hold each of the pendants at the chosen height. Support the wooden bar so that no strain is applied to the wiring when making the electrical connections. If necessary get a colleague to help. The luminaire is designed to be attached to an electrical supply of **220–240V AC 50Hz**.
3. Once the pendant drops are adjusted to the desired height and the electrical connection is made, tighten the screws provided through the wooden bar onto the ceiling to securely hold the fitting in place.
4. To fit the lampshades to the lamp holders, sandwich the brass top plate (A) of the lampshade between the two shade rings on the lamp holder (B). (*See additional installation instructions for [Urchin X-Small Linear Trio Light shade fitting](#)*). Repeat this stage for the following two lampshades. Screw in the light bulbs of your choosing. The luminaire has been designed to work with E27 **LED** light bulbs, up to a maximum of **25 Watts** each.
5. Turn the power supply on to complete installation.

\*\*\* If the external flexible cable or cord of this luminaire is damaged, it shall be exclusively replaced by the manufacturer or his service agent or a similar qualified person in order to avoid a hazard. \*\*\*

For more information on the installation of your product: [sales@tomraffield.com](mailto:sales@tomraffield.com) +44 (0)1326 722725